

FREE STANDING and CEILING SUPPORTED WORKSTATION CRANES



K-TRAC SERIES

**FEATURES**

- spans up to 45 feet »
- 250 lb. to 6000 lb. cap. »
- internal electric bar »
- headerless design »
- easiest installation »
- effortless movement »
- custom built to order »
- custom formed profile »
- true free-standing »







**Kundel Industries**, the world leader in custom cranes, continually strives to advance crane technology. Using state-of-art controls and the latest technology in materials, Kundel crane systems travel smoother and with less effort than any other crane on the market. Kundel Industries continues it's investment to building a better product by the recent addition in the roll forming of our K-Trac Crane. During this advancement we have not only increased our material gauge, but also our material grade. This will provide our customers with increased spans between supports

thereby increasing valuable floor space and decreasing cost. Custom Cranes are standard for Kundel. We feel that no two customer needs are the same and should not be treated the same, that is why we manufacture cranes tailor built to the customers specifications. K-TRAC enclosed track crane systems maximize floor space without an obtrusive supporting structure or tying back to existing structures. Pre-installed maintenance free internal electric bar replaces messy festoon cable systems and all Kundel crane systems come with all components completely assembled on the system allowing for easy installation.

**10 REASONS TO CHOOSE KUNDEL**

*KUNDEL - custom built to order*

1. True Free Standing - NO tie backs
2. NO Headers - Open ended
3. Spans up to 45' - longer
4. Capacities up to 3 TON - heavier
5. Internal Electric Bar - clean & maintenance free
6. Harness Electrical Connections - Quick hoist removal
7. Posts - cantilever; built in leveling adjustments
8. Coverage - Maximum due to short endtrucks
9. Joints - bolted SOLID
10. Sizes - Custom Built to job requirements

*Competition - pre-built kits*

1. Tie backs to building needed
2. Headers - closed off entry
3. Spans ONLY up to 30'
4. Capacities ONLY up to 2 ton - lighter
5. Internal Festoon - messy cables; stacker needed
6. Connections - slow & hard wired
7. Headers - rigid connection; no adjustments
8. Coverage - reduced due to long rigid endtrucks
9. Joints - tracks are clamped together
10. Sizes - Standard kit sizes; cut to fit on-site



**FREE STANDING**

**K-Trac** comes custom built straight from the factory floor. Each system is designed to customer specifications including runway length, bridge length, post height, hook height and even location of incoming electric. Prior to production a detailed print of the system layout is sent to the customer for approval. Once approval is met the system goes into production. At that time each of the rail sections are sheared to the exact length required for the job. The sections are then assembled and painted. Once cured the hardware is installed according to the customers print. This greatly speeds up installation time (no pallet of parts). Every K-Trac is fully expandable allowing it to be reconfigured or added on to at any time. K-Trac meets and exceeds all industry standards.

**DON'T SETTLE**

When it comes to buying a crane, you don't have to settle for an off-the-shelf kit anymore! Say "NO" to chop and fit. With Kundel, your crane system is custom built to your requirements. We feel that no two customers have the same needs, so why should you settle for something less than what you deserve... a crane system built just for you.



**CEILING MOUNTED**

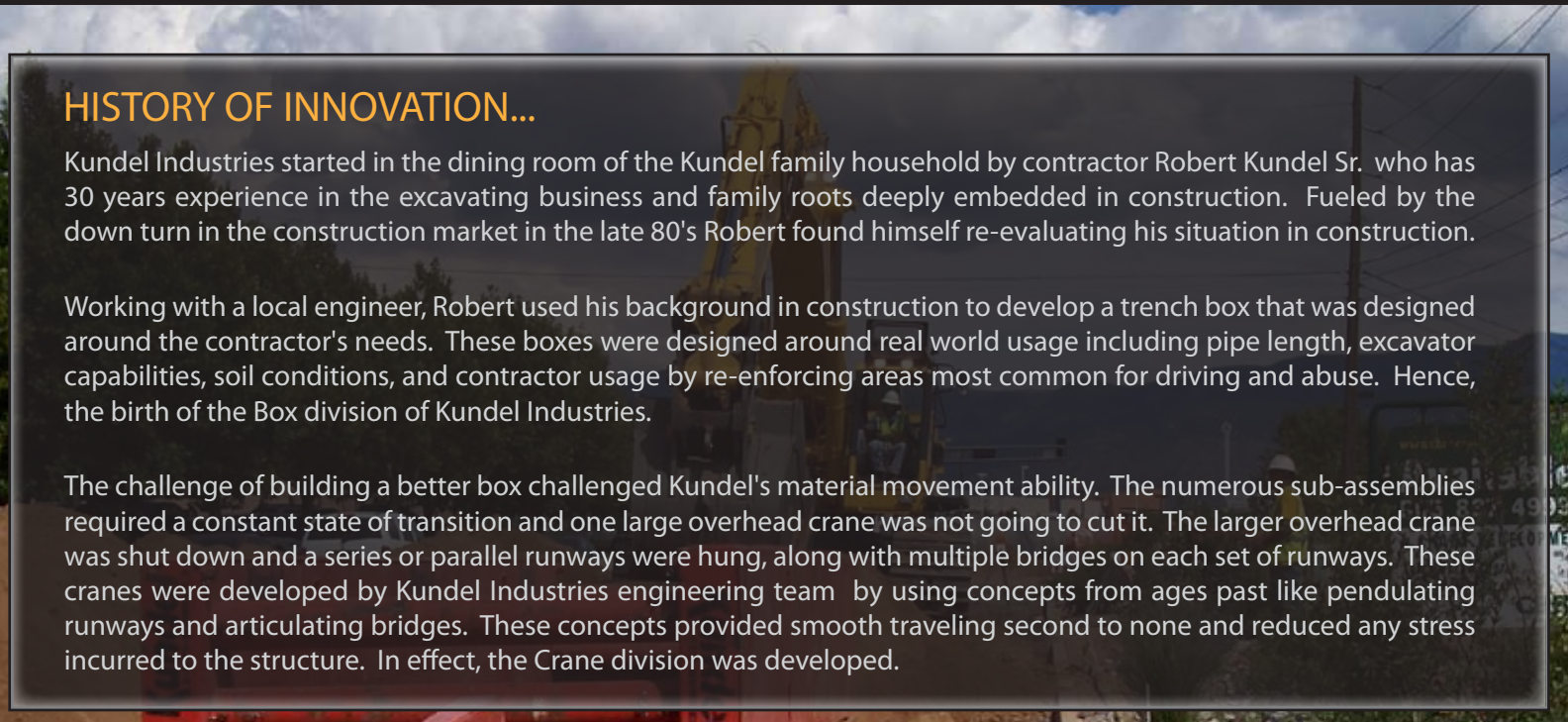

**HISTORY OF INNOVATION...**

Kundel Industries started in the dining room of the Kundel family household by contractor Robert Kundel Sr. who has 30 years experience in the excavating business and family roots deeply embedded in construction. Fueled by the down turn in the construction market in the late 80's Robert found himself re-evaluating his situation in construction.

Working with a local engineer, Robert used his background in construction to develop a trench box that was designed around the contractor's needs. These boxes were designed around real world usage including pipe length, excavator capabilities, soil conditions, and contractor usage by re-enforcing areas most common for driving and abuse. Hence, the birth of the Box division of Kundel Industries.

The challenge of building a better box challenged Kundel's material movement ability. The numerous sub-assemblies required a constant state of transition and one large overhead crane was not going to cut it. The larger overhead crane was shut down and a series or parallel runways were hung, along with multiple bridges on each set of runways. These cranes were developed by Kundel Industries engineering team by using concepts from ages past like pendulating runways and articulating bridges. These concepts provided smooth traveling second to none and reduced any stress incurred to the structure. In effect, the Crane division was developed.

**STANDARD FEATURES**

- Spans**  
Up to 45' on bridges and runways
- Electric**  
Internal Electric Bar (no messy festoon cords)
- Capacities**  
Up to 3 TON
- Material**  
80 grade high yield steel
- Components**  
Come pre-mounted
- Endtrucks and Trolleys**  
Shortest approach in the industry
- Installation**  
approx 1/2 that of the competition; can be relocated
- Posts**  
Solid heavy wall design; fully adjustable at base and top



Endtrucks and Trolleys

- Floor Plates**  
Level with no shimming & grouting
- Ball Joint Supports**  
Ensured to hang plumb and true
- Shape**  
Custom roll formed enclosed track
- Fit**  
Built to customers requirements
- Support Locations**  
Can be varied along the runway (not possible with headers)
- Durability**  
System does not wobble and does not need tied back
- Modular**  
Unit can be taken down and re-configured to meet new requirements

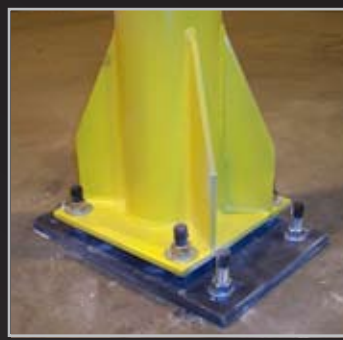

Post and Floor Plate Assembly



# CRANE ANATOMY

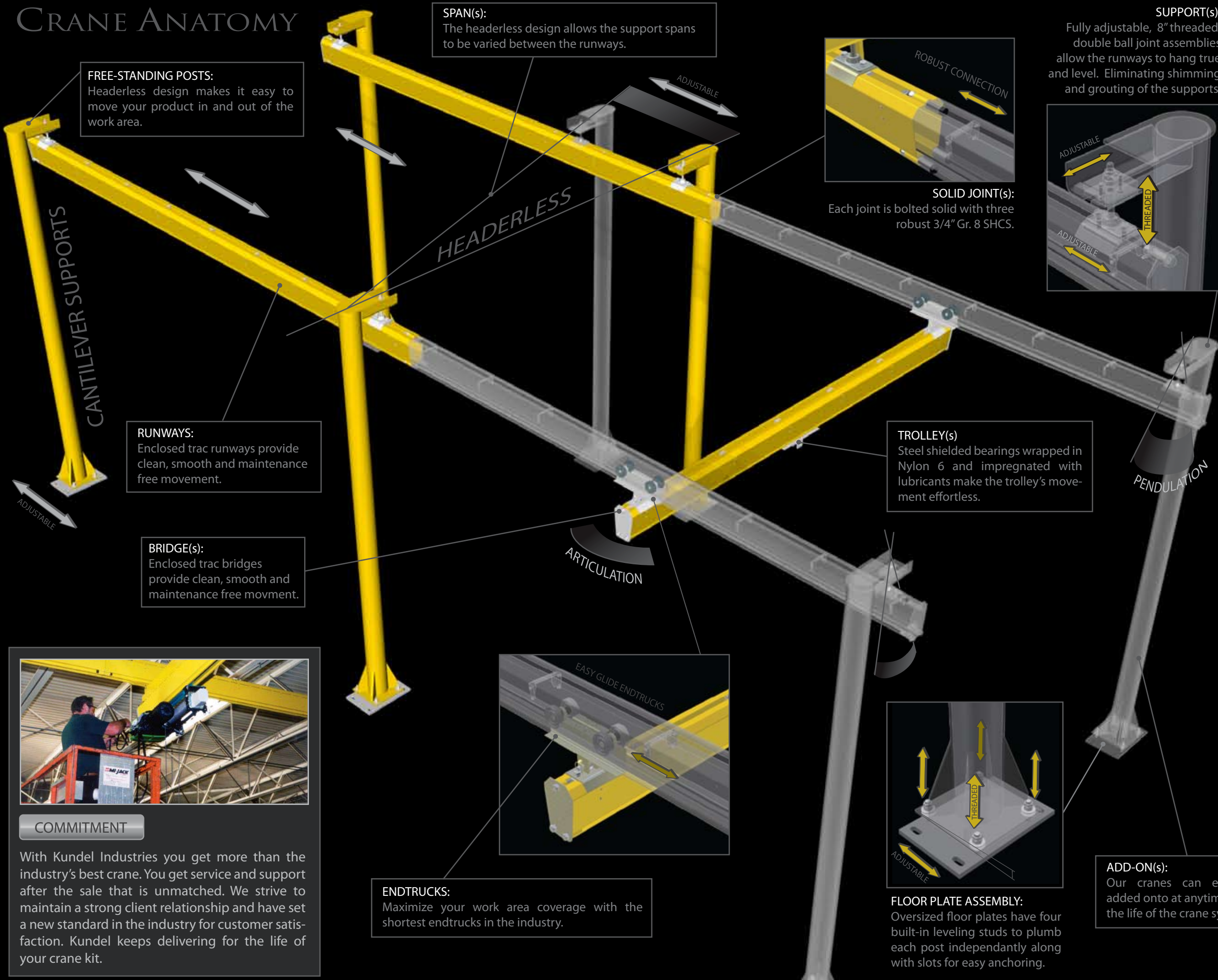

**FREE-STANDING POSTS:**  
Headerless design makes it easy to move your product in and out of the work area.

**SPAN(s):**  
The headerless design allows the support spans to be varied between the runways.

**SUPPORT(s):**  
Fully adjustable, 8" threaded, double ball joint assemblies allow the runways to hang true and level. Eliminating shimming and grouting of the supports.

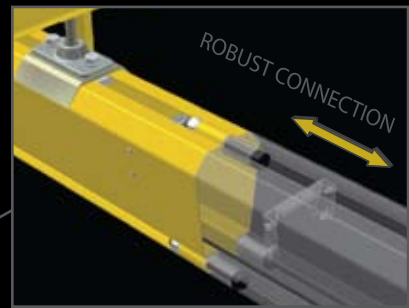

**SOLID JOINT(s):**  
Each joint is bolted solid with three robust 3/4" Gr. 8 SHCS.

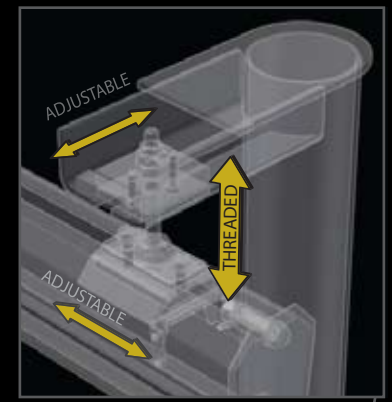

**RUNWAYS:**  
Enclosed trac runways provide clean, smooth and maintenance free movement.

**BRIDGE(s):**  
Enclosed trac bridges provide clean, smooth and maintenance free movement.

**TROLLEY(s)**  
Steel shielded bearings wrapped in Nylon 6 and impregnated with lubricants make the trolley's movement effortless.

**ENDTRUCKS:**  
Maximize your work area coverage with the shortest endtrucks in the industry.

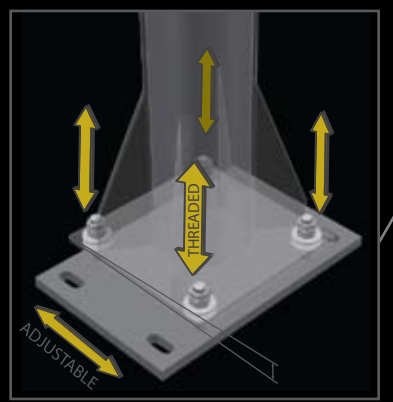

**FLOOR PLATE ASSEMBLY:**  
Oversized floor plates have four built-in leveling studs to plumb each post independently along with slots for easy anchoring.

**ADD-ON(s):**  
Our cranes can easily be added onto at anytime during the life of the crane system.

## TESTIMONIALS



**Heil Environmental - Jimmy Smith**  
We were impressed with how easy this crane moved after it was loaded. It's much easier than using a "jib crane" that goes off center and is hard to maneuver. Installing our Kundel cranes was easy. When we did have questions, they had the answers. From start to finish Kundel delivered a quality product with service to match. Safety, ease of use and increased production are the keys to our success.



**Waltco Truck Equipment - Marty Byner**  
With our customized Kundel Crane we're able to produce more "lift gates" faster. Kundel was able to build a crane that fit our production line. This not only made our job easier, it made our employees safer. Plus, Kundel keeps delivering with service and support after the sale. We not only got a great crane, we got a great crane company that cares about their customers and takes great pride in their product.

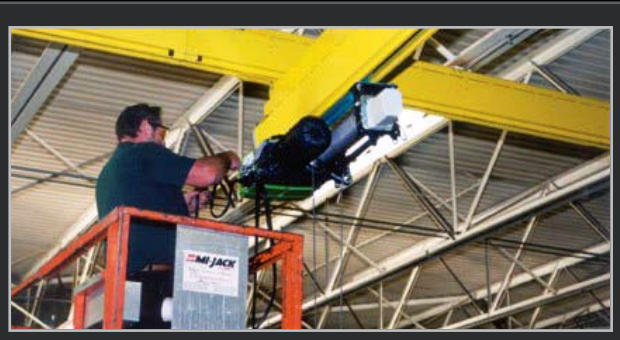

## COMMITMENT

With Kundel Industries you get more than the industry's best crane. You get service and support after the sale that is unmatched. We strive to maintain a strong client relationship and have set a new standard in the industry for customer satisfaction. Kundel keeps delivering for the life of your crane kit.





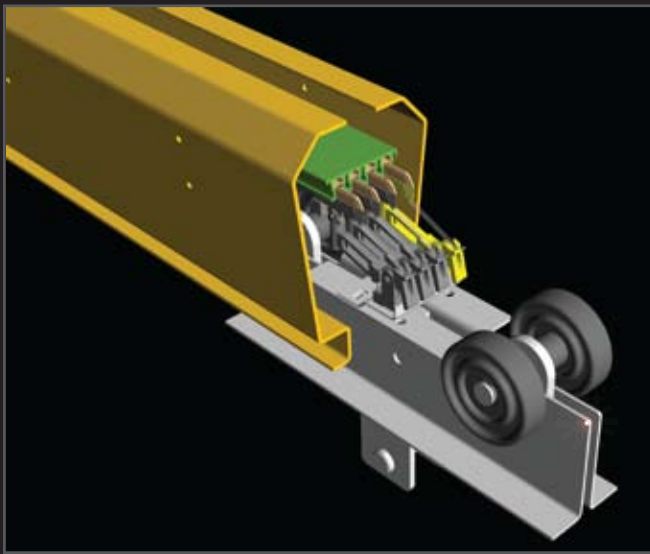

### POWER UP!

#### INTERNAL ELECTRICAL BAR:

No more messy festooning cables hanging down catching on your machines or exposed electrical track in your workstation area. With Kundel's internal electrical bar, power is gathered throughout the entire length of the system internally. Having the capability of handling 60 AMPS at 600VAC the internal electrical bar can handle multiple bridge applications with no problem. This gives the bridge(s) freedom to move the entire length of the workstation without worrying about festooning getting tangled up or gliders and trolleys not stacking up properly. Stop accommodating for stackers that take up valuable work space when floor space is at a premium.

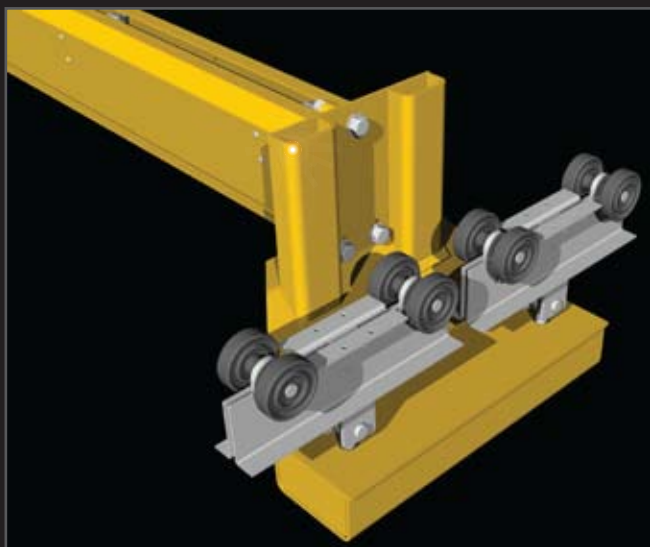

### LOW Headroom Applications

#### RAISED BRIDGE ENDS:

Low ceilings? Elevated obstructions? No problem. Kundel Raised Bridge Ends give you maximum lift for low headroom applications. Gain an additional 15" - 18" of trolley hook height with this option over the standard underhung workstation cranes. Independent dual endtrucks compliment the raised bridge design ensuring proper contact of wheels to the track surface. Each endtruck is equipped with a minimum of four wheels with double steel shielded bearings and a spherical connection to allow proper tracking of the bridge down the runway without binding under load.

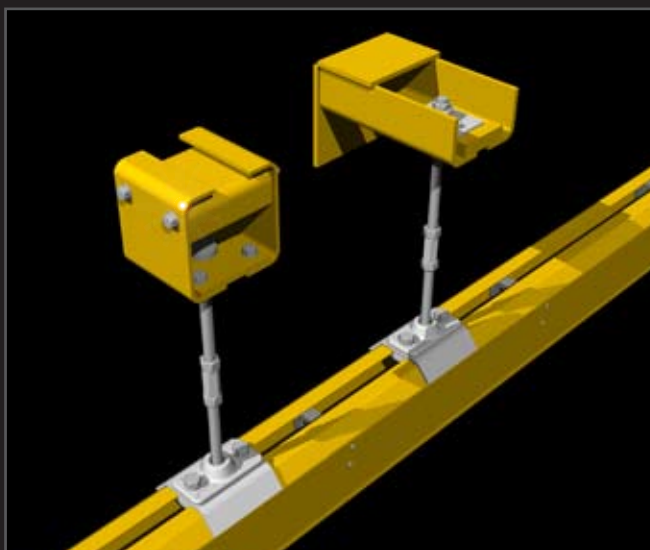

### Optional Supports

#### BEAM HANGERS AND WALL HANGERS:

Create an obstruction free workstation by utilizing pre-existing structures in your facility. Support your new Kundel Crane System by incorporating beam hangers, wall hangers or both. Posts, ceiling hangers, and wall hangers can all be combined on the same crane system to maximize efficiency of your floor space. The system cost can also be reduced by utilizing these hangers instead of support posts. Each hanger, whether for your ceiling or your wall, is custom built to your application needs.

### FREQUENTLY ASKED QUESTIONS:

#### WHAT DO I NEED TO KNOW BEFORE I PLACE AN ORDER?:

Understand that your order is not limited to an off-the-shelf kit and that you can specify the length, width, and height you need to fit your application.

#### DO CUSTOM LENGTHS COST MORE?:

Absolutely not. There is NO cut charge for custom lengths, nor is there any delay in your order due to special length or height requirements. Each rail section is cut to order from the profile inventory and assembled, painted and components are installed according to your order.

#### CAN I HAVE THE CRANE SYSTEM PAINTED A DIFFERENT COLOR?:

Yes. There is a minimal cost for special paint requests. In order to ensure proper coloration we will need either a detailed color code and or color swatch to duplicate the requested color into a paint mixture suitable for our painting process.

#### DO YOU SELL INTERNATIONALLY?:

Yes we not only have a vast national dealer network, but we also have international representation. Call for details.

#### IS THERE A DEALER IN MY AREA?:

We have over 2,500 locations that represent our product line along with on-line catalogs and websites. You can find a dealer in your area listed on our website at [www.kundel.biz](http://www.kundel.biz) under the "DEALERS" section. Our website is constantly being updated with new dealers, so if you do not find a dealer or representative in your area please call and we will provide you with that information along with having our local representative contact and set up a on-site visit.

#### WHAT KIND OF WARRANTY DOES THE K-TRAC COME WITH?:

#### Kundel Industries Crane Warranty

Kundel Industries, Inc. warrants to the original purchaser its Products to be free of defects in material and workmanship for a period of two years unlimited use, and five year (10,000 hours of use), from the date of purchase. Kundel Industries, Inc. will replace any parts found to be defective. Replacement parts are warranted for the remainder of the original warranty period. Warranty does not cover the installation of the replaced part.

If any Products prove defective within its original warranty period, it should be returned, if needed, to any Authorized Distributor, transportation prepaid with proof of purchase or Warranty Certificate.

Kundel also offers a Limited Lifetime Warranty on defects in material and workmanship\*\*.

This warranty does not apply to Products which Kundel Industries, Inc. determined to have been misused or abused, improperly maintained by the user, or where the malfunction or defect can be attributed to the use of non-genuine Kundel Industries, Inc. Product or Part. The warranty does not apply to normal wear and tear on Crane system.

Kundel Industries, Inc. makes no other warranty, and all implied warranties including any warranty of merchantability or fitness for a particular purpose are limited to the duration of the expressed warranty period as set forth above. Kundel Industries, Inc. maximum liability is limited to the purchase price of the Product and in no event shall Kundel Industries, Inc. be liable for any consequential, indirect, incidental, or special damages of any nature rising from the sale or use of the Product, whether based on contract, tort, or otherwise.

\*\*To qualify for the Limited Lifetime Warranty, the Crane System must have an annual inspection by a certified Kundel dealer. Normal wear and tear not included.

#### CRANES

"Using the latest materials and technology, Kundel custom crane systems travel smoother and with less effort than any other crane on the market."

#### DEALERS

"Kundel manufactures cranes that are not only user friendly, but dealer friendly. All components come pre-installed and installation time is about half that of a competitive workstation crane."

#### ABOUT US

"Kundel is a family based company that strives to build the best equipment available in the markets they serve. We invite you to become a part of the family and build a better tomorrow with Kundel products."

#### OPTIONAL EQUIPMENT not shown:

Catilevers - Up to 4' and more depending on capacity

External Air festoon kits - Nycoil tag line kits up to 30' in length

External Electric Kits - Tag line up to 30'; over 30' requires "C" track option

#### ADDITIONAL KUNDEL CRANE PRODUCT LINES:

SnapTrac - Up to 1/2 Ton



T-Trac - Up to 10 Ton



# BODE

MATERIAL HANDLING SOLUTIONS

BodeEquipment.com

(800)797-5699