

Quick-Lift Arm

QL A 50i

Intelligent lifting device which meets the highest standards of ergonomics, working environment, safety and efficiency.

Unique integrated mechanical, electric, pneumatic swivel simplifies use and minimizes maintenance.

Easy to use thanks to outstanding responsiveness, regardless of load weight.

Exceptional safety achieved using our intelligent control systems.

The best auto balance available regardless of load weight.

High reliability and low power consumption results in superior cost efficiency.

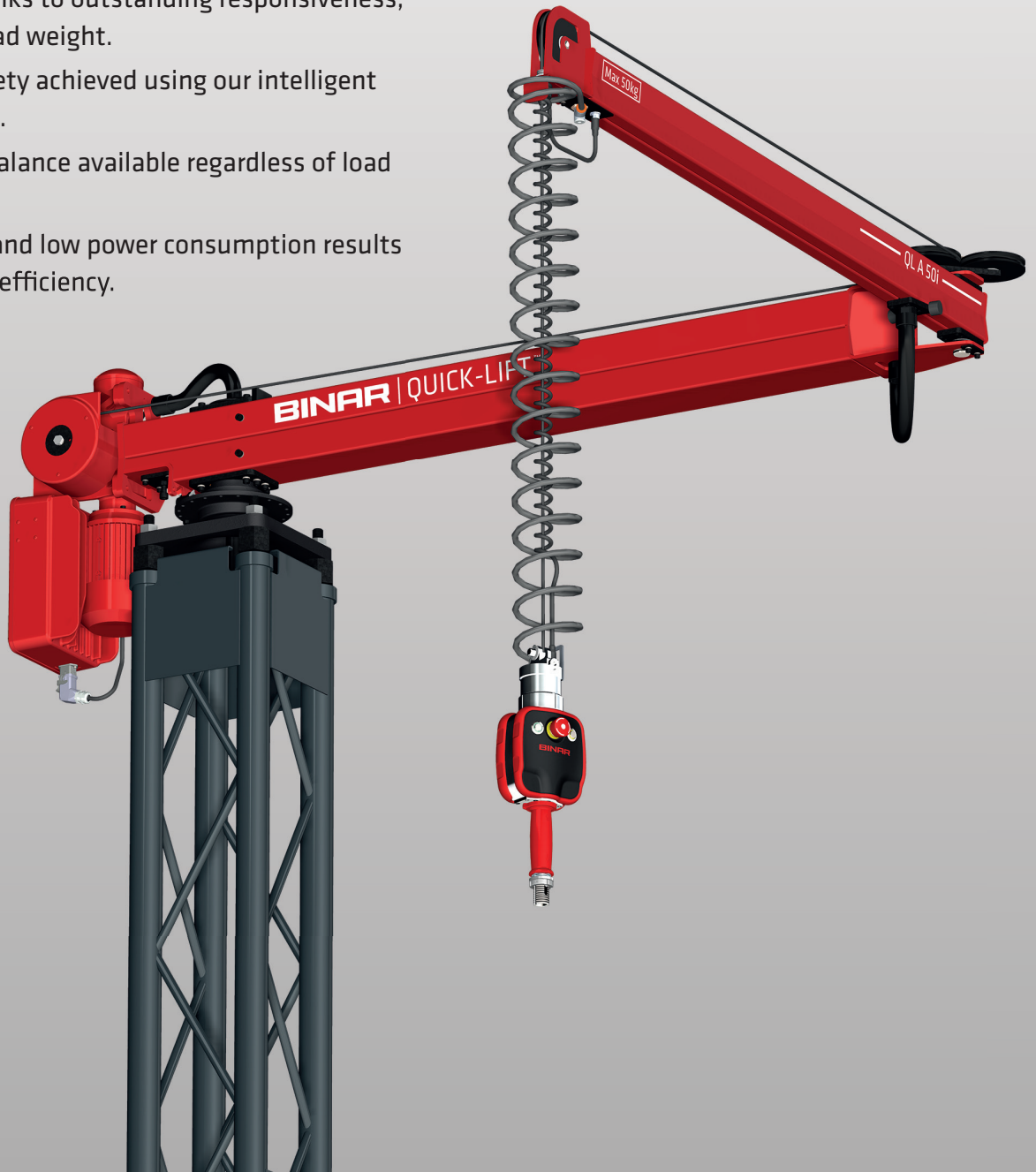

BINAR

Improving your productivity

Quick-Lift Arm

QL A 50i

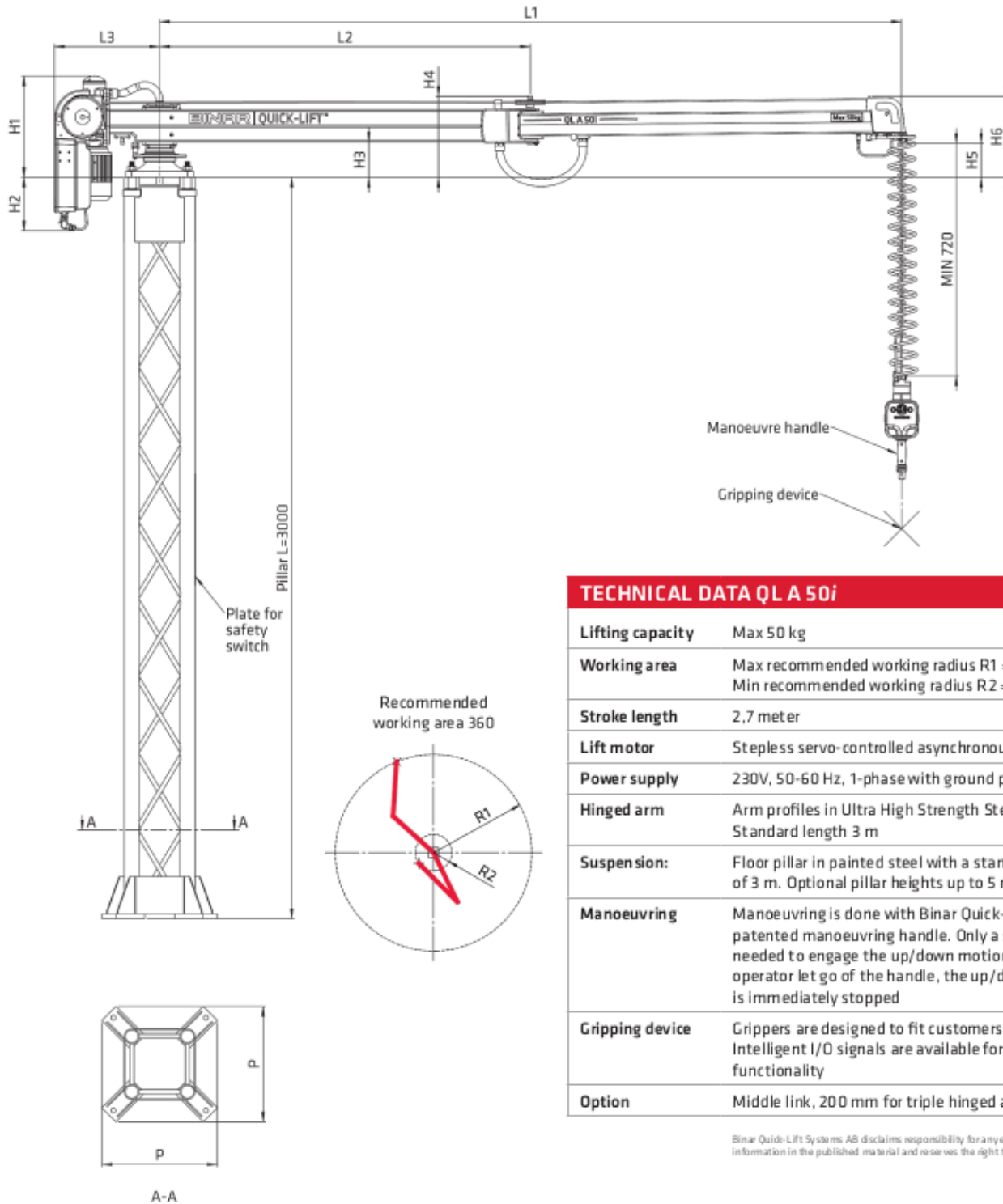

TECHNICAL DATA QL A 50i

Lifting capacity	Max 50 kg
Working area	Max recommended working radius R1 = L1 - 300 mm Min recommended working radius R2 = See chart
Stroke length	2,7 meter
Lift motor	Stepless servo-controlled asynchronous motor
Power supply	230V, 50-60 Hz, 1-phase with ground protection, 10A
Hinged arm	Arm profiles in Ultra High Strength Steel (UHSS) Standard length 3 m
Suspension:	Floor pillar in painted steel with a standard height of 3 m. Optional pillar heights up to 5 m
Manoeuvring	Manoeuvring is done with Binar Quick-Lifts patented manoeuvring handle. Only a small force is needed to engage the up/down motion. When the operator let go of the handle, the up/down motion is immediately stopped
Gripping device	Grippers are designed to fit customers need. Intelligent I/O signals are available for optimum functionality
Option	Middle link, 200 mm for triple hinged arm

Binar Quick-Lift Systems AB disclaims responsibility for any errors or incomplete information in the published material and reserves the right to make changes.

Part.no	L1	L2	L3	H1	H2	H3	H4	H5	H6	P	R1	R2
013600	3000	1500	426	410	217	142	329	138	329	467	2700	800



BodeEquipment.com
(800) 797-5699

BINAR
Improving your productivity