

# NER/ER Cylinder Control Electric Chain Hoists with Hook and Lug Suspensions



NER003SCC

We have expanded the benefits of the ergonomically designed cylinder control into our full-featured NER/ER Series of electric chain hoists. For three-phase applications requiring ease of control, one-handed operation, fast lifting speeds and heavy duty production, these hoists will increase productivity, add to operator comfort and answer your ergonomic needs.

## Features and Benefits

### Easy Access Suspension

External pins allow for quick change from hook to lug for trolley mount configurations on most models.

### Green Initiative

Built smarter without the use of harmful materials. Environmentally friendly. RoHS compliant.

### Notched Hook and Latch System

Provides positive closing and improves resistance against lateral forces.

### Limit Switches

Low-profile upper and lower limit switches are standard.

### Extended Chain Life

Decreased chain wear as a result of a revolutionary heat treatment process, improved material and chain size.

### Low/High Speeds

Rocker switch above handgrip on dual speed models allows quick selection of low or high speed.

### High Air Flow

Cooler motor and brake attributed to an engineered motor fin, fan blade and fan cover design.

### Unique Load Sheave

Increased number of pockets reduce chain vibration and increase chain life. 5 pockets standard; 6 pockets on smaller body hoists.

### Friction Clutch and Load Brake

Friction clutch is standard on NER/ER models and friction clutch with mechanical load brake standard on ER models. Carbon friction material provides consistent performance over a wide temperature range.

### Standard Count Hour Meter

Records and displays the number of lowering starts and hoist on time which is valuable for preventive maintenance. Integral to VFD on dual speed models.

### Removable Bottom Hook

Permits insertion of below-the-hook devices.

### Contactors

Mechanically interlocked, heavy-duty contactors on single speed models.

### High Strength, Corrosion and Wear Resistant Load Chain

Grade 80, super strength, nickel-plated load chain, certified to DIN standards, uses unique technology to greatly increase resistance to fatigue and wear.

### Dual Speed VFD

Under-the-cover VFD standard for dual speed hoists. Speed ratio is 6:1 with adjustability up to 12:1.

### “The Guardian”: Smart Brake Technology

A current driven electromagnetic brake does not release unless the motor is energized. 10 year hoist brake warranty.

### Unique Cylinder Control

In-line handgrip permits one handed operation. Available on hoist or as a kit for field installation.

## Standard Hoist Specifications

### Capacity Range

NER/ER – 1/8 Ton – 1/4 Ton

### Standard Voltage

208-230 / 460-3-60  
Optional voltages available  
Dual speed models are not reconnectable

### Control Voltage

110V (optional 24V)

### Duty Cycle\*

Single Speed – 60 Min.  
Dual Speed – 30/10 Min. with VFD

### Classification\*

ASME H4  
ISO M5  
FEM 2m or 1Am

### Ratings

Hoist – IP55  
Pendant – IP65

### Upper/Lower Limit Switch

Overwinding / overlifting device  
Standard on all models

### Chain Falls

Single chain fall

### Standard Lift

6' (longer lifts not available)

### Standard Reach

9' (approx)  
(reach equals lift plus headroom)

### Standard Power Supply Length

15' (longer lengths available)

### Mounting

Hook, lug or trolley

### Standard Pendants

Single speed: 2-button (momentary contacts)  
Dual speed: 2-button (momentary contacts) with emergency On/Off (maintained contacts)

### Chain Containers

Standard  
Plastic

### Operating Conditions

Recommended for -4° to +104° F and humidity of 85% or less.

### NER vs. ER Features

ER model has same high-quality features as NER plus the following:

- Second brake—Weston-style mechanical load brake

\*See page 59 for additional information.

HARRINGTON ELECTRIC CHAIN HOISTS



NER003SCC

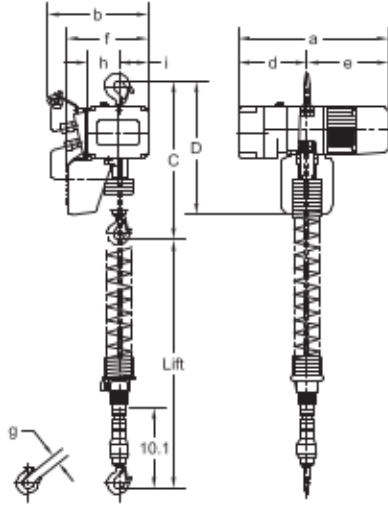

NER003SCC

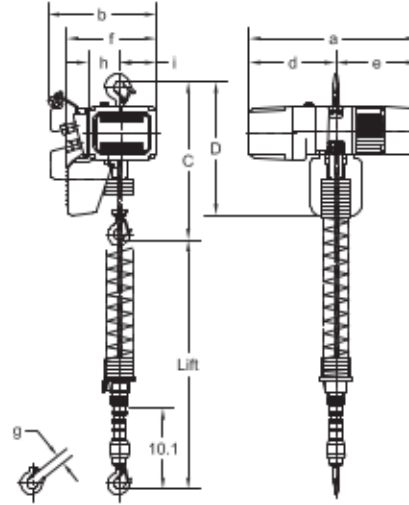

NER003SDCC

Dimensions for NER/ER Cylinder Control Model (inches)

NER/ER CYLINDER CONTROL — SINGLE SPEED SPECIFICATIONS

Cap. (Tons)	Product Code	Standard Lift (ft)	Lifting Speed (ft/min)	Lifting Motor 3 Phase 60 Hz			Load Chain Diameter (mm) x Chain Fall Lines	Net Weight (lbs)	
				Output (Hp)	Rated Current (amps)			NER	ER
					@208 - 230V	@460V			
1/8	(N)ER001HCC	6	55	0.75	3.4	1.7	4.3 x 1	66	68
1/4	(N)ER003SCC	6	36	0.75	3.4	1.7	4.3 x 1	66	68

SINGLE SPEED DIMENSIONS

Cap. (Tons)	Product Code	Headroom C (in)	D (in)	a (in)		b (in)		d (in)		e (in)	f (in)		g (in)	h (in)	i (in)	
				NER	ER	NER	ER	NER	ER		NER	ER			NER	ER
1/8	(N)ER001HCC	41.9	19.3	18.8	22.2	12.6	13.6	8.6	12.0	10.2	10.2	11.2	1.1	3.9	3.7	4.6
1/4	(N)ER003SCC	41.9	19.3	18.8	22.2	12.6	13.6	8.6	12.0	10.2	10.2	11.2	1.1	3.9	3.7	4.6

NER/ER CYLINDER CONTROL — DUAL SPEED SPECIFICATIONS

Cap. (Tons)	Product Code	Standard Lift (ft)	Lifting Speed (ft/min)	Lifting Motor 3 Phase 60 Hz*			Load Chain Diameter (mm) x Chain Fall Lines	Net Weight (lbs)	
				Output (Hp)	Rated Current (amps)			NER	ER
					@208 - 230V	@460V			
1/8	(N)ER001HDCC	6	55/9	0.75	3.6	1.8	4.3 x 1	64	68
1/4	(N)ER003SDCC	6	36/6	0.75	3.6	1.8	4.3 x 1	64	68

\*Although both 208/230 & 460 Volts are shown together, the motors are NOT reconnectable. Speed ratio is 6:1 with adjustability up to 12:1.

DUAL SPEED DIMENSIONS

Cap. (Tons)	Product Code	Headroom C (in)	D (in)	a (in)		b (in)	d (in)		e (in)	f (in)	g (in)	h (in)	i (in)
				NER	ER		NER	ER					
1/8	(N)ER001HDCC	41.9	19.3	21.1	22.2	13.6	10.9	12.0	10.2	11.2	1.1	3.9	4.6
1/4	(N)ER003SDCC	41.9	19.3	21.1	22.2	13.6	10.9	12.0	10.2	11.2	1.1	3.9	4.6



MATERIAL HANDLING SOLUTIONS

BodeEquipment.com

(800) 797-5699