



Guardrails

A Safe Workplace



Guardrail Applications

Conveyor Perimeter Protection Guardrails	3
Spiral Conveyor Protection Guardrails	4
Staircase Entrance Guardrails	5
Machine Guard Safety Barriers	6
Electrical Panel Guardrails	7
First Aid Station Protection Guardrails	8
Restroom Area Guardrails	9
End-of-Aisle Guardrails	10
Loading Dock Protection Bollards	11
Warehouse Separation Guardrails	12
Traffic Control Pedestrian Barriers	13
Accelerated Production	14



Guardrails

A Safe Workplace



Conveyor Protection

Guardrails

Trouble-free for your peace of mind. Install a heavy-duty guardrail system and create a protective shield between your workers and your equipment.

Promote a safe and efficient work environment with Cogan heavy-duty guardrail. Built from the best

quality materials, our guardrails are strong, adaptable and when properly installed, engineered to withstand a 10,000-lb impact at 4 mph. That means the equipment on your shop floor will be protected from traffic accidents and other hazards. Use Cogan heavy-duty guardrails to safeguard machinery, conveyors and inventory areas. Our guardrail barriers work equally well protecting mezzanines, offices, walls, heating and cooling equipment, and computer control centers.

Spiral Conveyor Guardrails

Structurally solid and impact-resistant, keep your load on track with Cogan heavy-duty guardrail for spiral conveyors.

Designed to direct in-plant traffic circulation, our guardrails define, control and protect important areas in your warehouse. Create an impenetrable wall of steel around your conveyor system. Your machinery will remain shielded from even the toughest forklift collisions. Improve employee well-being and reduce job-related stress. Avoid costly repairs and downtime. Cogan heavy-duty guardrail barriers deliver around the clock protection to keep your property safe and your mind at ease.



Promote a safe and efficient workplace. Protect staircases and other entrance ways from collision accidents with Cogan heavy-duty guardrail.

Unimpeded access to your mezzanine platform is essential to maintain productivity. Damaged

staircase components are not only costly to repair, but can pose a number of safety hazards. When an elevated work area is structurally compromised, your employees are much more susceptible to fall accidents and personal injury. With over 11% of forklifts in the United States involved in some kind of accident each year, the potential for such occurrences is high. Cogan heavy-duty guardrails shield vulnerable property to promote a safe and efficient work environment.

Staircase Entrance

Guardrails





Equipment Safety Guardrails

Cogan equipment safety guardrail are your first line of defense against dangerous collision accidents.

Versatile, affordable and extremely durable, our equipment safety guardrail directs the flow of traffic in your warehouse to keep employees and in-plant vehicles away from hazardous or structurally sensitive work areas. Prevent injury, costly repairs, and downtime. Use Cogan guardrail to safeguard machinery, conveyors, rack aisle ends, inventory areas and loading docks. All machine guard barriers are sealed in a powder-coated yellow paint finish for maximum visibility.

Electrical Panel Guardrails

Protect vulnerable electrical equipment from collision damage with Cogan heavy-duty electrical panel guardrail.

In a busy warehouse setting, accidents can happen without warning. Exposed or otherwise compromised electrical wires are not only costly to repair, but can be extremely dangerous for your workers. Install our heavy-duty guardrails and direct in-plant traffic away from hazardous or potentially volatile electrical equipment. The tough-as-nails construction works around the clock to keep your property intact and your workplace safe, productive and profitable.





First Aid Station

Guardrails

Make employee safety a top priority. Secure your first aid area, improve on-site safety and prevent injury with Cogan heavy-duty guardrail barriers.

Every employee has the right to a sound work environment that provides adequate measures

to treat and prevent injury. Secure your first aid area and improve on-site safety with Cogan guardrail barriers. According to OSHA, approximately 85 workers are killed and another 34,900 are injured in fork truck collisions each year in the United States. Engineered to absorb heavy impact, our guardrail barriers reduce the occurrence and costly effects of such accidents. You benefit from increased productivity and employees who know that their well-being is a top priority.



Restroom Area Guardrails

The effective direction of warehouse traffic is necessary to ensure safety and efficiency in the workplace.

Maintain clear access to restroom facilities with Cogan heavy-duty guardrails. Top notch construction means our heavy-duty guardrails are exceptionally strong and adaptable to accommodate all of your guarding needs. Use Cogan guardrails to guide in-plant vehicles away from employee rest areas. Avoid damage to plumbing equipment and shield personnel from collision accidents when entering and exiting the restroom.

24/7 protection where you need it, when you need it. Secure vulnerable rack-aisle-ends with Cogan single rail guardrail barriers.

Install Cogan single rail heavy-duty guardrail and protect your racking units from traffic accidents.

The most vulnerable part of any racking system are the bases and posts exposed on busy aisle ends. Left open to warehouse traffic, one damaged post can compromise the structural integrity of an entire racking unit. Designed to run low to the ground, our single rail guardrails shield sensitive rack-aisle-ends from fork lifts and other in-plant vehicles. Structural uprights will remain intact preventing costly repairs and unwanted damage to your inventory.

End-of-Aisle

Guardrails





Loading Dock Bollards

Ideal for protecting loading dock doors, Cogan bollards shield your work space inside and out from collision damage.

Our 4 ½" diameter steel tube bollards are welded to 10" x 10" baseplates and painted with a durable, powder-coated, safety-yellow finish made to stand up to your traffic. If heavy-duty protection is what you need, we also offer an oversized 6" diameter bollard welded to a 12"x12" base plate for extra security. Cogan bollards are in-stock and ready to ship. Benefit from a safer work environment that protects your people, products and profits, eliminating costly repairs.



Warehouse Separation

Guardrails

Ideal when you need a sturdy barrier between processes. Separate and control important areas in your warehouse with Cogan guardrail.

Ideal when you need a sturdy barrier between processes, our guardrails create aisle ways to

guide in-plant traffic around secured sections in your warehouse. Forklift accidents are a common and costly occurrence. Divide and organize storage zones and protect manufacturing equipment and work cells from collision damage. The corrugated steel construction gives our guardrail extra durability while minimizing width to maximize floor space. You benefit from increased efficiency, enhanced aisle flow, and improved worker safety.

Traffic Control

Pedestrian Barriers

Identify safe walkways and keep your employees out of harm's way with Cogan pedestrian barriers.

Pedestrian barriers are perfect for controlling high-traffic areas in your plant or warehouse. Indicate safe corridors and limit pedestrian traffic around dangerous equipment or inventory. All Cogan pedestrian barriers are designed with 2-rail and 3-rail options to meet BOCA and OSHA safety standards. No welding, threading, drilling or bolting required for assembly. Our slip-on pipe connections can easily be dismantled and reused for other applications again and again.





Accelerated Production

2-Week Delivery on Select Items

Need it fast? Accelerated Production orders are assembled from raw components that we keep in stock. This allows us to fast-track your order through our abbreviated production process.



Accelerated Production
2-Week Delivery on Select Items

HEAVY-DUTY GUARDRAILS

Item Description

A. Rails

- 2' Rail (19" exact length)
- 3' Rail (31" exact length)
- 4' Rail (43" exact length)
- 5' Rail (55" exact length)
- 6' Rail (67" exact length)
- 7' Rail (79" exact length)
- 8' Rail (91" exact length)
- 9' Rail (103" exact length)
- 10' Rail (115" exact length)

Item

- QS-GR2
- QS-GR3
- QS-GR4
- QS-GR5
- QS-GR6
- QS-GR7
- QS-GR8
- QS-GR9
- QS-GR10

B. Columns & Accessories

- Double Rail Column (centered baseplate)
- Double Rail Column (offset baseplate)
- Single Rail Column (centered baseplate)
- Single Rail Column (offset baseplate)
- Lift-Out Brackets (pair)
- 5/8" x 4 1/2" Floor Anchors (4x/pkg)

- QS-GPDC
- QS-GPDO
- QS-GPSC
- QS-GPSO
- QS-GL1
- QS-GFA5

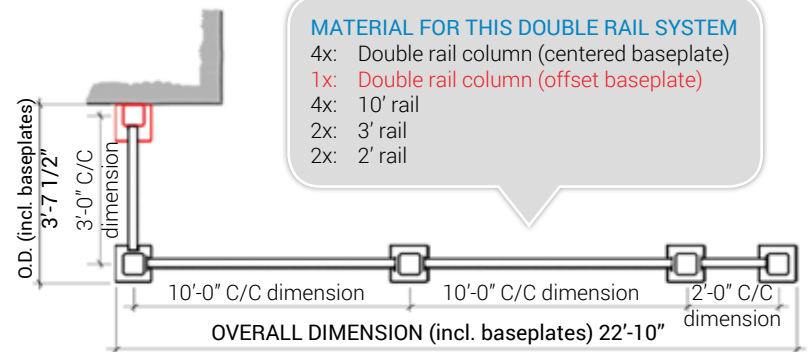

SPECIFICATIONS

13-gauge steel / unassembled components

Absorbs impact of a 10,000 lb load at 4 mph. 13-gauge roll-formed steel, 12" high profile, 1/4" thick end plates punched with two $\varnothing 9/16$ " connection holes. 5" x 5" seam welded square columns welded to a 10" x 10" x 1/2" baseplate with $\varnothing 3/4$ " mounting holes. Black plastic post caps. Install with floor anchors (sold separately).

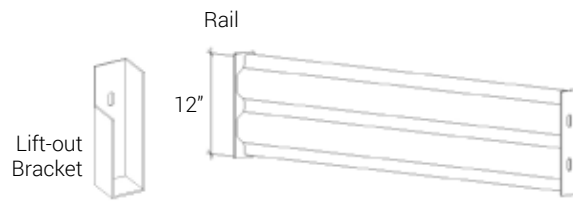
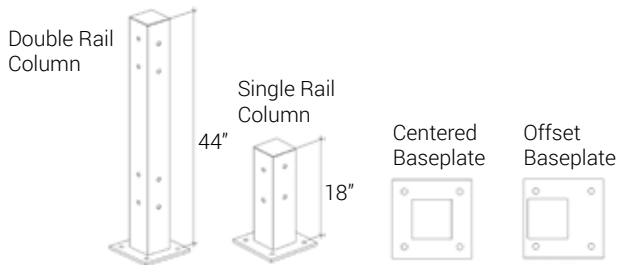

FINISH
Powder-coated safety yellow



Bollards

SPECIFICATIONS

1/8" thick steel tube
4 1/2" or 6" diameter
Sturdy welded baseplate is made of 1/2" thick steel plate. Includes $\varnothing 3/4$ " bolt holes for floor anchors (sold separately). Black plastic top cap.

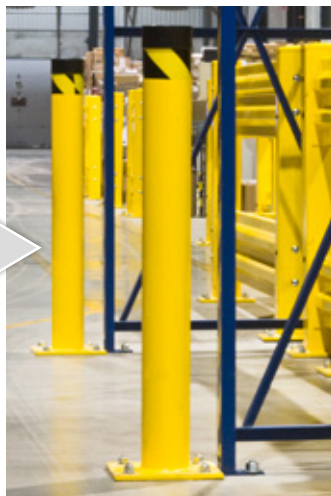

Item Description

- 42" High Bollard (4 1/2" dia. + 10" x 10" baseplate)
- 5/8" x 4 1/2" Floor Anchors (4x/pkg)

Item

- QS-B42
- QS-GFA1

FINISH

Powder-coated safety yellow

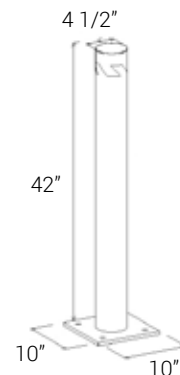

Self-Closing Safety Gates

SPECIFICATIONS

Adjustable length 22" to 36" or 33" to 48"

Exclusive Universal Mounting Adapter

Spring-loaded hinges for 90° reversible rotation

Spring-loaded hinges allow the gate to close automatically, reducing the risk of accidentally walking or backing into the opening. The flexibility of the spring allows the gate to swing back and forth, making both sides easily accessible. Compatible with heavy-duty guardrail, pedestrian rail and mezzanine systems.

FINISH

Powder-coated safety yellow

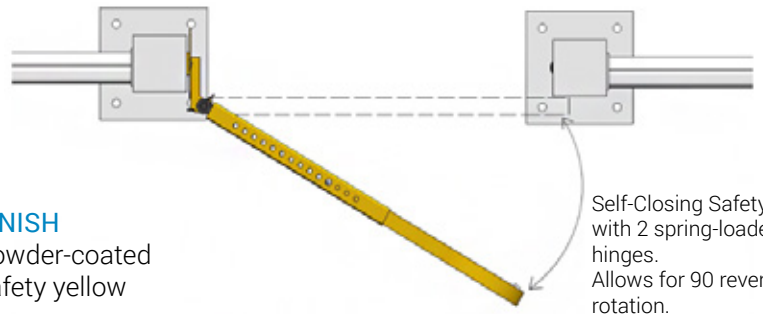

Plan View

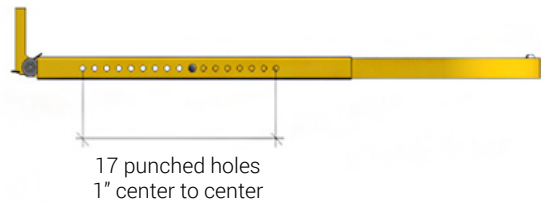
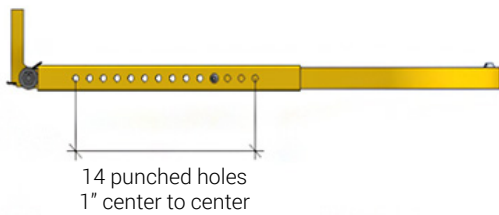

Overall Length

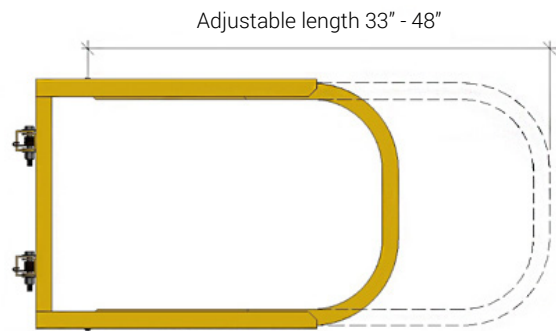
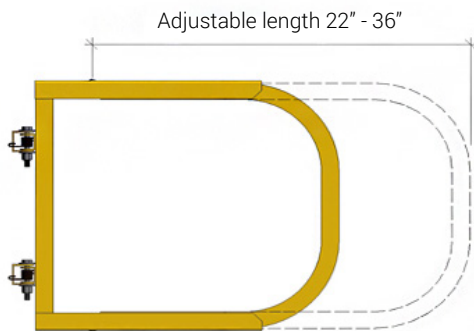

Standard Colors

Standard colors are applied to all products and are automatically included in the material price on your quote. Unless otherwise specified, all standard colors are powder-coated for a durable, long-lasting and maintenance-free paint finish.

Guardrails



Safety Yellow



Cogan
Since 1901

BODE

MATERIAL HANDLING SOLUTIONS

DESIGN | LAYOUT | SALES | INSTALLATION | SERVICE

BodeEquipment.com
(800)797-5699

green
Marketing