



Drive-In Storage Systems



RIDG.U-RAK®

RIDG-U-RAK

Drive-In & Drive-Thru Storage Systems

- Maximum Density Storage
- LIFO & FIFO Pallet Storage
- EasyLift Truck Access

Drive-In rack is a high-density (LIFO) system best suited for last-in, first-out storage requirements. Drive-thru systems are similar to drive-in rack but can be (FIFO) accessed from either end and can be first-in, first-out.

These storage rack systems feature narrow pallet-storage lanes running perpendicular to the working aisles. Pallets are stored on the floor and on the parallel rails. Drive-In is a good choice for building inventories that ship periodically with low SKU items.

Features:

- Provides more storage space than standard pallet rack
- Fewer aisles required
- Lift truck accessible

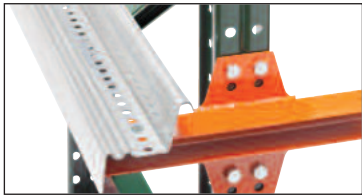

Rolled Rail System



Optional Space Saver Structural Rail System

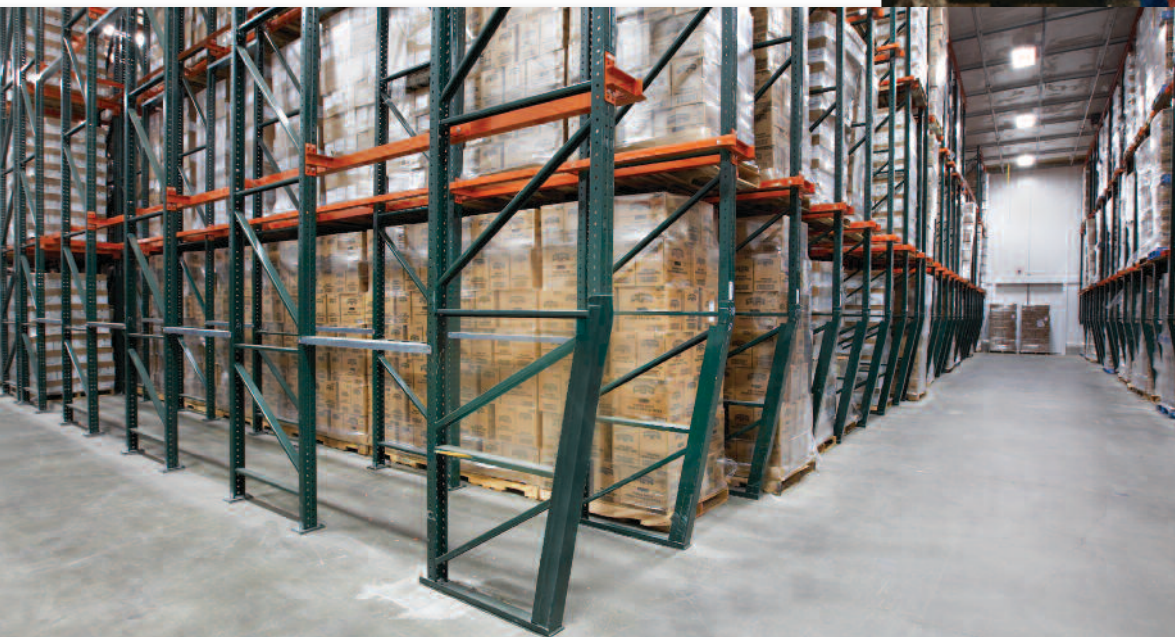

SpaceSaver Rail - System shown above with optional slant back frames.





Rolled Rail System -
Provide superior strength and torsion resistance on heavy loads.



Lift Trucks -
Enter the storage system placing the load on the floor or on the pallet rails.



Maximum Density

Drive-In Systems increase storage density by eliminating aisles and are multiple pallet positions deep.

Maximum Pallet Density

Offers numerous high-strength, durable design options.



Drive-In, Drive-Thru Rack Systems

For the right application a Drive-In system is a cost effective, high density system where you have low SKU counts and selectivity is less important. The illustration to the right, depicts a warehouse with one main aisle separating two drive-in systems 8 pallet positions deep by four pallets high. Selectivity in this example is 13%... 4 high, divided by 32 pallet positions, (8 deep x 4 high) equals 13%.

High-density drive-in systems are ideal for LIFO storage applications having few items or SKUs and not particularly time sensitive products. Operators fill the system back to front to access all the pallet positions. Particular attention to proper loading, pallet specifications and lift truck dimensions is required.

Drive-In systems are commonly found in factories, warehouses, coolers and freezers.

Features:

- Roll formed or structural steel upright frames
- Durable galvanized rolled rails resist abrasion and offer superior torsion resistance
- Optional Space Saver rails maximize vertical space



Rolled Rail system with optional floor guides.

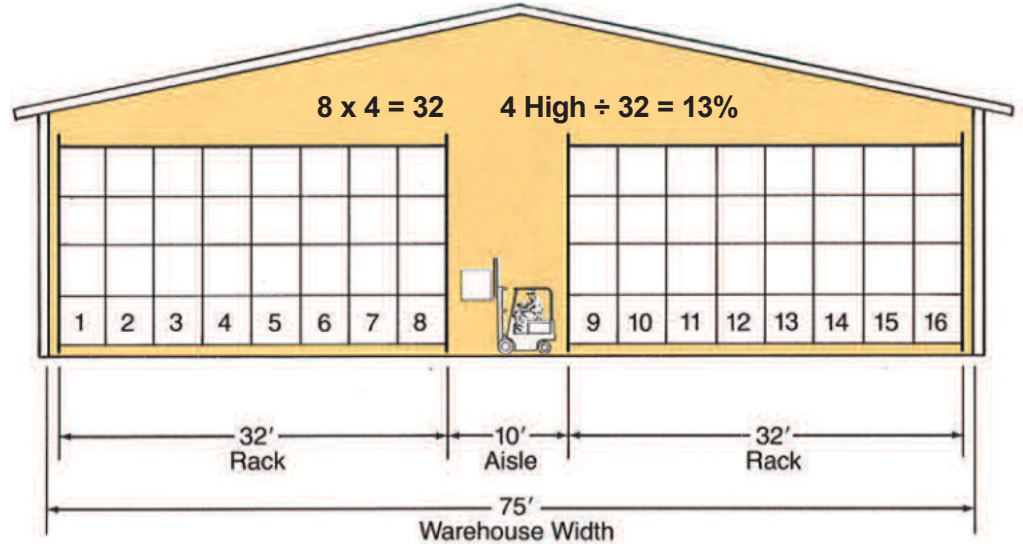

16 Pallet locations across width of warehouse

13% Selectivity



Operator drives directly into the pallet storage lane.



Narrow pallet lanes provide high-density storage.

Drive-In System Components



Bolted-In Top Braces - Tie the uprights together for increased system rigidity and stability.



Bolted Connection- These rigid rail support arms are superior to other arms as these provide a bolted connection with grade-five hardware.

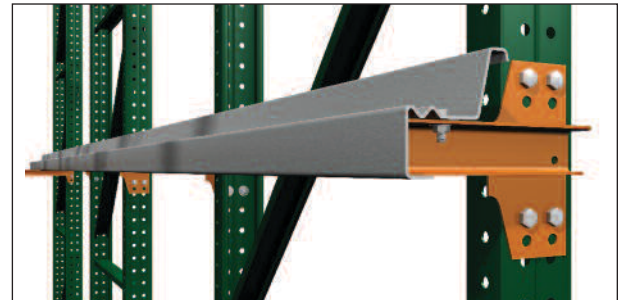

Rolled Rails- This roll formed rail profile provides exceptional strength, load capacity and resists torsion when fully loaded.



Basic Beams - Provide system rigidity and rail support in the back of the system.

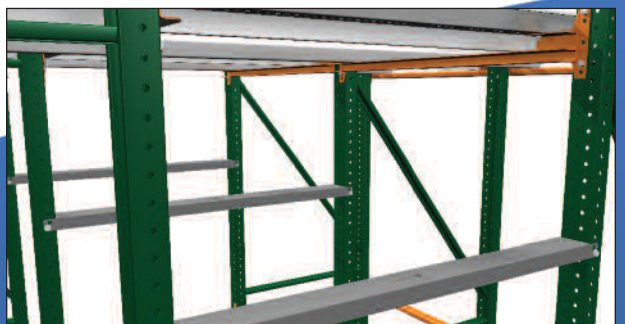

Frames - Row spaces are used to create positive frame locations.

Ridg-U-Rak Drive-In Systems are engineered to provide exceptional structural integrity and durability



Rail Systems & Uprights

Roll Formed Uprights & Rails

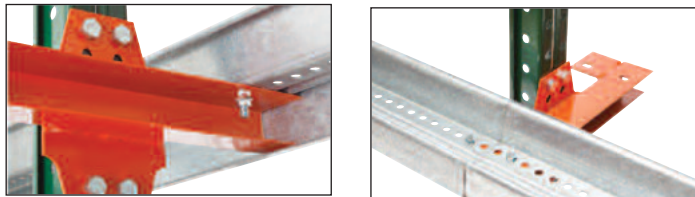

SpliceArm - Each end of the rolled rail is bolted onto a splice support.

Structural Uprights & Rails

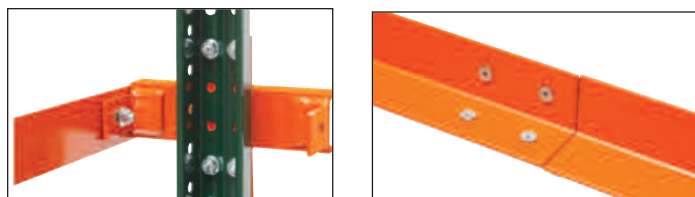

Splice Connection - Space Saver rail splices are achieved using 4 bolts. Rail support & arms for both systems are secured with grade-five hardware for maximum load carrying capacity.

RIDG-U-RAK Drive-In Systems are available in roll formed or structural steel upright frames with rolled rails or space-saver structural rails.

Roll Formed Rails - Provide maximum load capacity and low torsional rotation when fully loaded. RIDG-U-RAK's wide-base profile improves pallet placement and its galvanized finish resists abrasion often associated with Drive-In systems.

Space Saver Rails - Made of structural angle, this design maximizes the available vertical space. These rails reduce vertical clearance by 3" per pallet level.

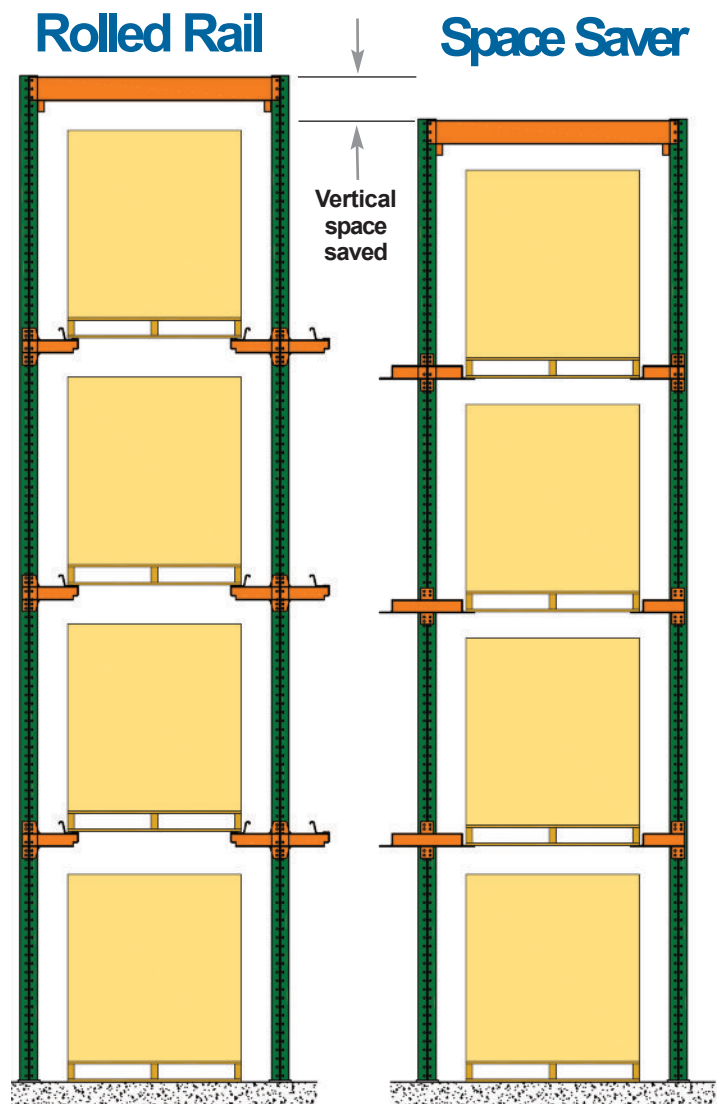

The above illustration demonstrates rolled rail and space saver rail with the same number of pallet positions, exhibiting the vertical space differential for comparison.

Design Considerations for Drive-In Layouts

Configurations & Dimensions Critical for Design

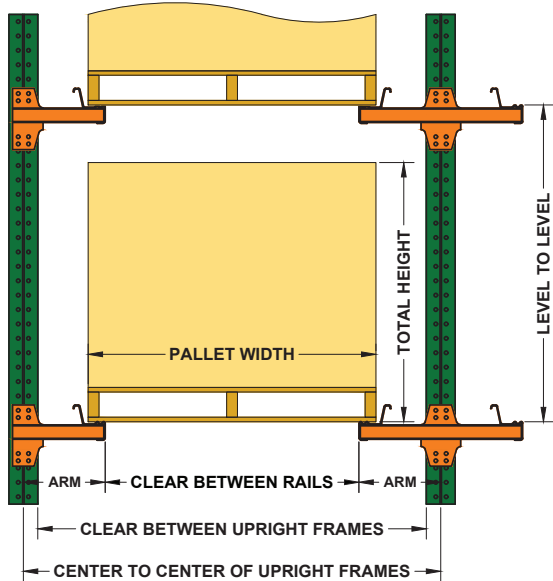

Pallets



RIDG-U-RAK recommends adherence to the National Wooden Pallet and Container Association (NWPCA) guidelines for pallet design and specifications. Traditionally, the accepted standard has been the Grocery Manufacturers' Association (GMA) pallet. The Grade A GMA Pallet features:

- 7 boards on top
- 5 boards on bottom
- Average top deck spacing 2.5" to 3.5"
- 3 stringers (1-1/2" x 3-1/2" ea)
- 4 way entry
- Pallets must be in good condition

Lift Truck Information

Ensure the lift truck can fit between the upright frames and can pass between the rails. It is also important that the lift truck has sufficient lift height to reach the highest rail level and has the capacity to lift the load safely.

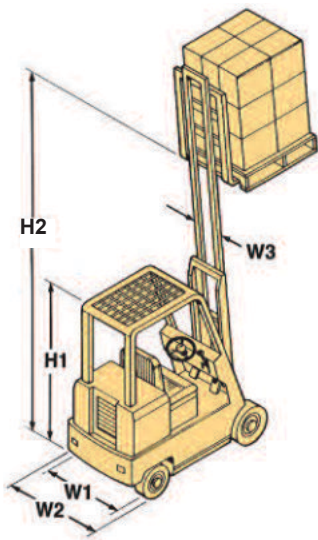

Load Information

As is the case with strict adherence to pallet specs, it is important to consider the load width, depth, height and weight to design the Drive-In system.

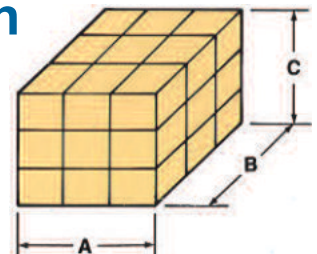

Upright Frame Options

Choose from four different upright column profiles.

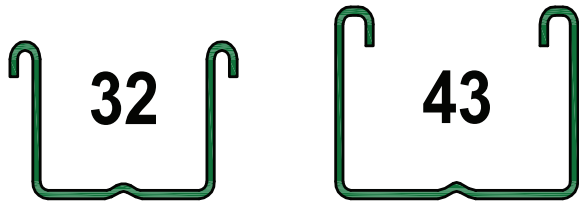

Drive-In Accessories

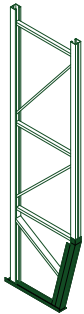

Aisle Entry Set Backs - Slant back frames provide extra distance and reinforcement to reduce accidental lift truck impact damage.

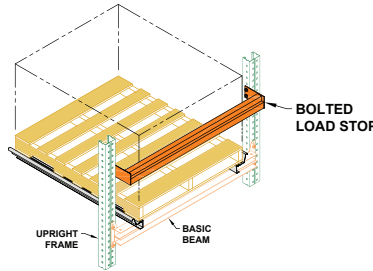

Load Stops - Attach to the upright frames and make contact with the load on the pallet.

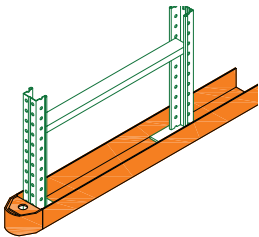

Floor Guides - Run the depth of system to help guide the fork truck in the Drive-In storage lane and reduce the incidence of internal upright impact damage.

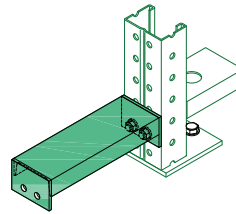

G.R. - Structural - Heavy duty row spacer that serves as a guide rail.

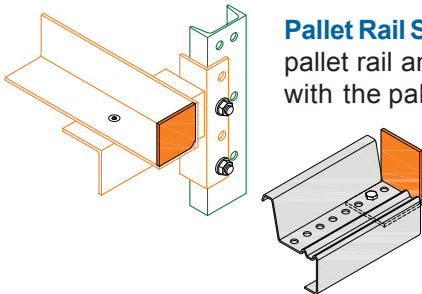

Pallet Rail Stops - Attach to the pallet rail and make contact with the pallet.

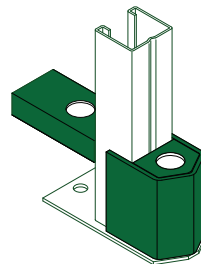

Deflector Options - Drive-In front column protector.



Famous for integrity for 75 years

For more information,
visit Ridgurak.com or call 866.479.7225



DESIGN | LAYOUT | SALES | INSTALLATION | SERVICE